

DATA SHEET

File No : LM-DS-629 Page : 1 of 5

REV : A DATE : 2017-2-25

DATA SHEET

L T L M - R 0 5 H C E - 0 0 2

DATA SHEET

File No : LM-DS-629 Page : 2 of 5

REV : A DATE : 2017-2-25

Part No:
LTLM-R05HCE-002

Features

- * High intensity LED lamp
- * $\varnothing 5\text{mm}$ round shape
- * UV resistant epoxy

Applications

- * LED Screen
- * Illumination

Absolute Maximum Ratings (Ta=25°C)

Parameter	Symbol	Max	Unit
Power Dissipation	P_D	100	mW
Peak Forward Current *	I_{FP}	100	mA
Continuous Forward Current	I_F	20	mA
Reverse Voltage	V_R	5	V
Operating Temperature Range	T_{opr}	-25°C to +80°C	
Storage Temperature Range	T_{stg}	-40°C to +100°C	
Lead Soldering Temperature Δ	T_{sol}	260	°C

* Duty ratio max 1/10 Pulse Width max. 0.1ms;

Δ At the position of 4mm from the bottom of the package within 5 seconds.

Package Dimensions

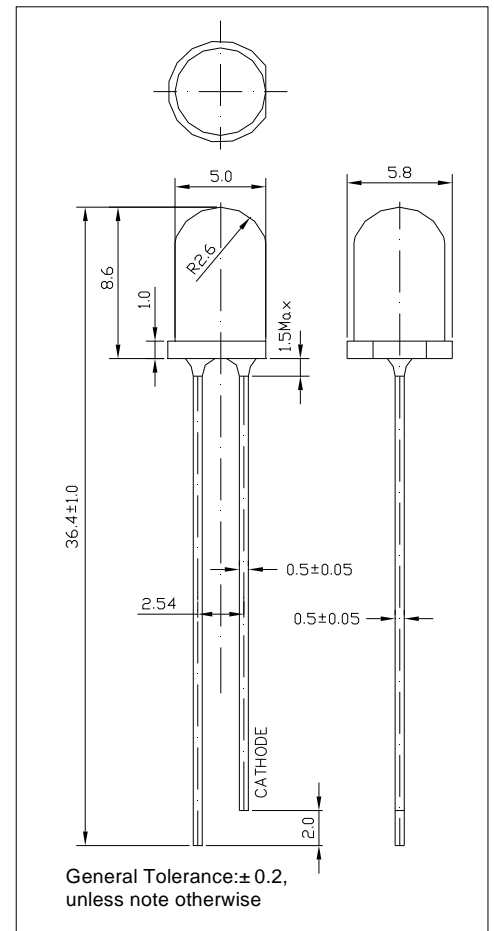

Unit : mm

Tolerance are ± 0.2 , unless note otherwise

Electrical Optical Characteristics

(Ta=25°C , @IF=20mA)

Part No.	Material	Lens	Emitting Color	Forward Voltage (v)		Luminous Intensity (mcd)		Dominant Wavelength (nm)		Viewing Angle ($2\theta_{1/2}$)
				Min	Max	Min	Max	Min	Max	
LM-R05HCE-002	InGaN	Water Clear	Bluish Green	2.8	3.6	7223	12480	500	509	30°

DATA SHEET

File No : LM-DS-629 Page : 3 of 5

REV : A DATE : 2017-2-25

BIN Table : (Test at 20Ma)

VF (v)	
Color	Range
V1	2.8-3.0
V2	3.0-3.2
V3	3.2-3.4
V4	3.4-3.6

IV (mcd)	
Code	Range
25	7223-8667
26	8667-10400
27	10400-12480

Wd (nm)	
Code	Range
H1	500-503
H2	503-506
H3	506-509

Error range :

- Luminous Intensity (IV) $\pm 10\%$, Forward Voltage (VF) ± 0.1 , Wavelength (Wd) $\pm 1\text{nm}$

Caution in ESD :

1. Static Electricity and surge damages the LEDs. It is recommended to use a wrist band or anti-electrostatic glove when handling the LEDs. All devices、Equipment and machinery must be properly grounded.
2. When inspecting own final products on which LEDs were mounted, It is easy to find static-damaged LEDs by light emission test at lower current (below 1mA is recommended) .
3. Damaged LEDs will show some unusual characteristics such as leak current remarkably increases, starting forward voltage becomes lower, or the LEDs get unlighted at the low current.

DATA SHEET

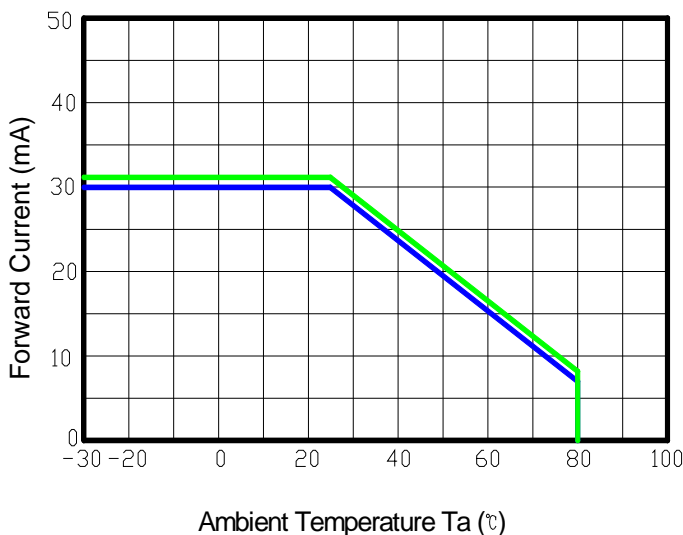
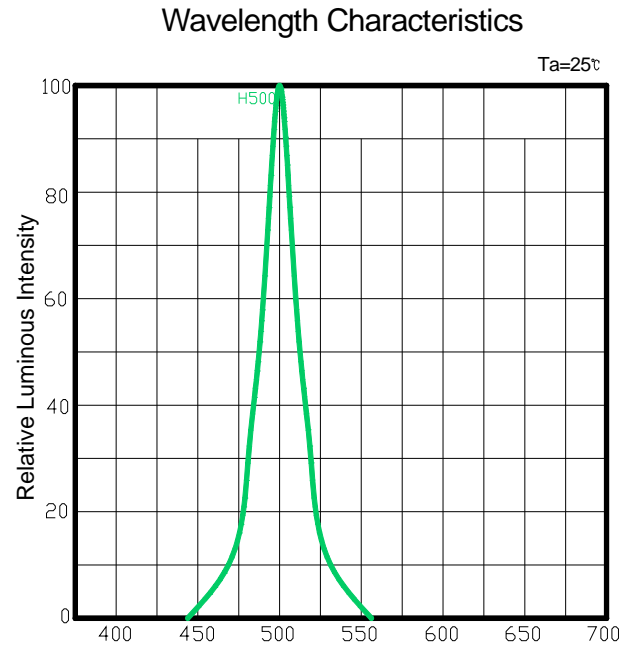
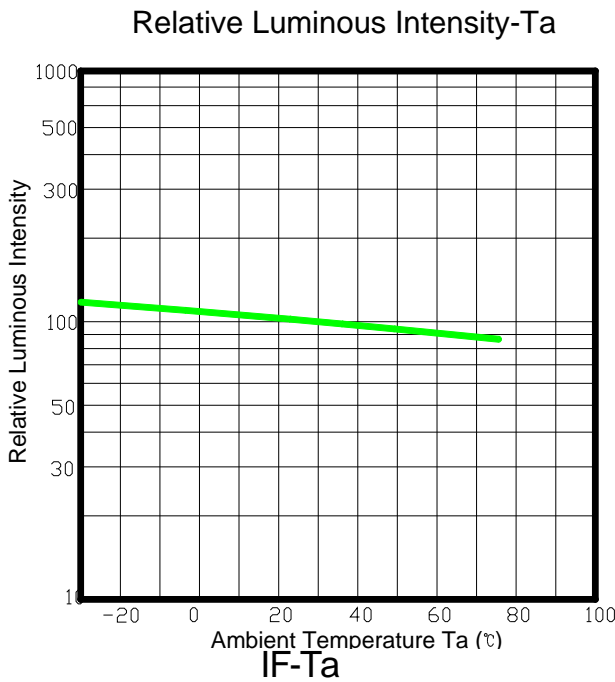
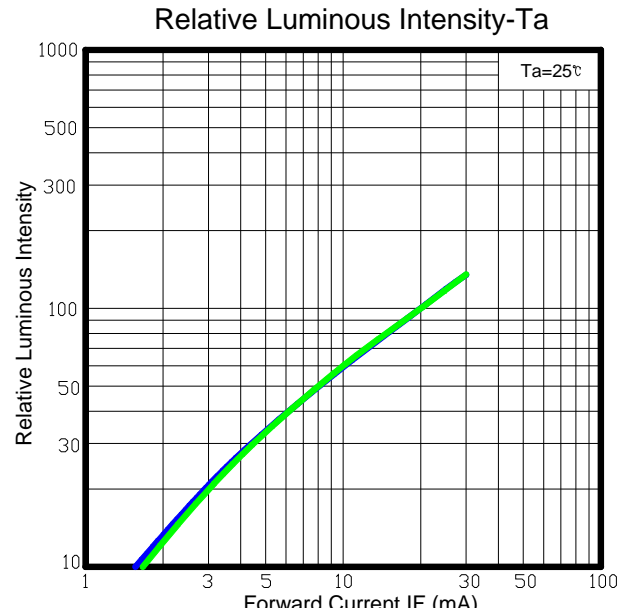
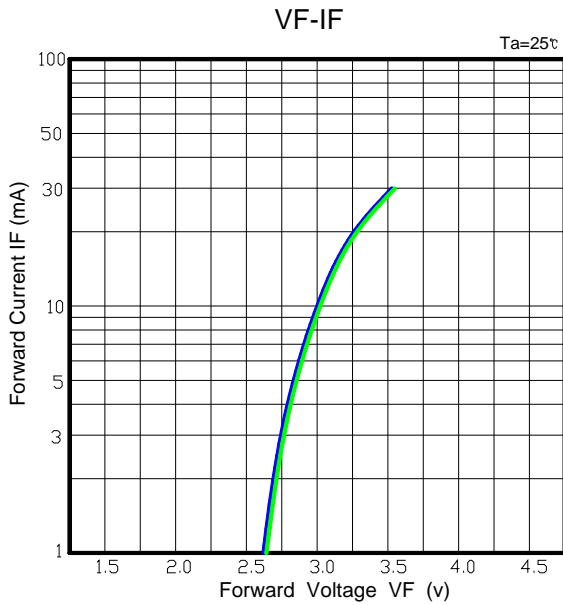

DATA SHEET

File No : LM-DS-629 Page : 5 of 5

REV : A DATE : 2017-2-25

Reliability Test

Classification	Test Item	Test Conditions	Sample Size	Num of Damaged	Reference Standard
Endurance Test	Operating Life	$I_F=30mA$ 1000Hrs	22	0	MIL-STD-750:1026 MIL-STD-202:107D JIS C 7021:B-4
	High Temp. High Humidity Storage	$85\pm5^\circ C$ 85-90% RH 1000Hrs	100	0	MIL-STD-202:103D JIS C 7021:B-11
	Hi-Temp. Storage	$100\pm5^\circ C$ 1000Hrs	100	0	MIL-STD-750:2031 MIL-STD-202:210A JIS C 7021:B-10
	Low-Temp. Storage	$-55\pm5^\circ C$ 1000Hrs	100	0	JIS C 7021:B-12
Environmental Test	Temperature Cycling	$-40\pm5^\circ C$ 30min Room Temp. 5min $100\pm5^\circ C$ 30min 100 Cycles	100	0	MIL-STD-750:1051 MIL-STD-202:107D JIS C 7021:A-4
	Thermal Shock	$-30\pm5^\circ C$ 5min $100\pm5^\circ C$ 5min 100 Cycles	100	0	MIL-STD-750:1051 MIL-STD-202:107D JIS C 7021:A3
	Solderability	$230\pm5^\circ C$ Dwell Time $\leq 5sec$	22	0	MIL-STD-202:208D MIL-STD-750:2026 MIL-STD-883:2003 JIS C 7021:A-2
	Solder Resistance	$260\pm5^\circ C$ $10\pm 1sec$	22	0	MIL-STD-750:2031 MIL-STD-202:210A JIS C 7021:A-1

Criteria for Judging The Damage:

Item	Symbol	Test Conditions	Criteria for Judgment	
			Min	Max
Forward Voltage	V_F	$I_F=20mA$	-	U. S. L*1.1
Reverse Current	I_R	$V_R=5V$	-	U. S. L*2.0
Luminous Intensity	I_v	$I_F=20mA$	L. S. L*0.7	-

PS: U. S. L. :Upper Standard Level L. S. L. :Lower Standard Level